



WEEE Directive 2012/19 / EU on Waste Electrical and Electronic Equipment

Waste electrical equipment should not be disposed of with other household waste. Please recycle it. Please contact your local authority for the required information.



www.aurael.ru



Due to continuous product development and improvement, all specifications are subject to change without notice.

©2020 AURA Electronics Inc. All rights reserved.

AURA[®]

OWNER'S

MANUAL

VENOM-12
VENOM-15

SUBWOOFER SPEAKER

WARNING!

PLEASE READ CAREFULLY BEFORE USING

Thank you for choosing the AurA subwoofer speaker!
 We are sure that you will get the expected level of quality and technical characteristics!
 Please read this manual carefully before installing the speaker!

Package bundle

Check the package contents of the subwoofer and make sure that the package contains:

1. Subwoofer
2. Instruction, warranty card
3. Car sticker
4. Fasteners

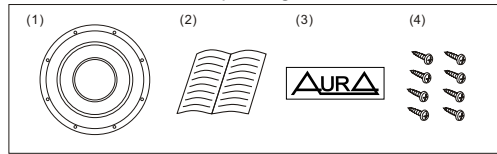

The package of the device are subject to change without notice.

Precautions

This user manual contains important safety advice and information on the correct use of the device.
 Please follow all instructions in this manual carefully.

1. When installing the device, avoid places with high temperature, humidity, or places where there is a lot of dust.
2. Make sure that the device and especially its installation accessories are out of the reach of children.
3. Do not drop the device and take care not to subject it to shock, as this may damage it.
4. Do not disassemble the device yourself. This could void the warranty.
5. Do not use alcohol, thinner, or benzine to clean the parts of the device. Use only a dry, soft cloth for cleaning.

Installation sizes

	VENOM-12	VENOM-15
Diameter, A	330	397
Diameter, B	286	349
Diameter, C	198	198
Height, D	95	95
Installing depth, E	203	212
Height, F	17	18
Xmax	30	30
Hole diameter	305	372

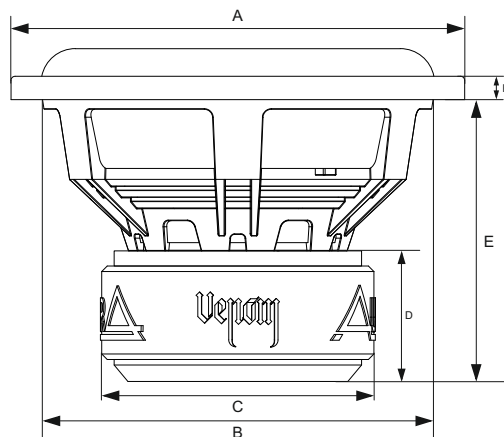

Connection options

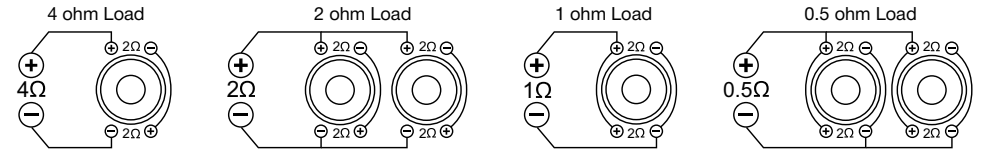

Recommended slotted chassis sizes

Model:	Body volume, l.	External sizes of the case (Width x Height x Depth)	Internal sizes of the slotted port Port (Width x Height x Length)
VENOM-12	65 l.	650x380x330 mm	60x340x550 mm
VENOM-15	103 l.	750x430x390 mm	70x390x590 mm

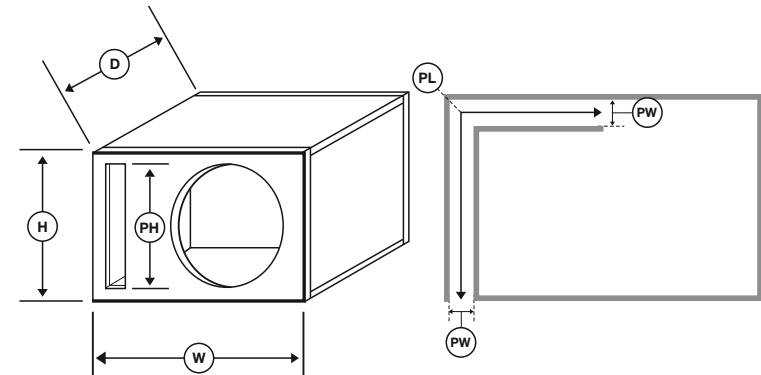

Technical features

	VENOM-12	VENOM-15
Diameter:	12" (30,5 cm)	15" (38 cm)
RMS / MAX Power:	1501 w / 3001 w	1501 w / 3001 w
Frequency range:	30-400 Hz	30-400 Hz
Sensitivity:	84,4 dB	86,5 dB
Resistance:	2x2 Ohm	2x2 Ohm
Voice Coil Diameter:	3" (76 mm)	3" (76 mm)
Magnetic system weight:	220 Oz (6,2 kg)	220 Oz (6,2 kg)
Resonant frequency (Fo):	30 Hz	31,7 Hz
Mechanical Q factor (Qms):	2,848	3,121
Electrical Q-factor (Qes):	0,580	0,768
Total Q factor (Qts):	0,482	0,616
Equivalent volume (Vas):	38,57	70,35
Mass of the moving system (Mms):	230,2 g	308,97 g
Force factor (BL):	16,41	16,98
Coil resistance, Ohm (Re):	1,9 + 1,9	1,9 + 1,9
Effective diffuser area (Sd):	471 cm ²	779 cm ²
Suspension flexibility, mkm / H (Cms):	122,23	81,57
Reference efficiency (No):	0,174%	0,28%
Xmax (one way):	30 mm	30 mm

